

PRIME XL

TECHNICAL INFORMATION

Dimensions	2.30 x 2.30 x 1.00 m
Jets	110
Shell	Coril® / White or Sterling Silver
Panels	Alupanels
Weight without water	450 Kg
Weight with water	2250 Kg
Volume	5.3 m3

EQUIPMENT SPECIFICATIONS

Seats	6 (1 lounged)
Filter	2 (5.5 m2)
Circulation / Massage Pump	1 – 60 W
Massage Pump	3 – 2200 W
Blower	1 – 850 W
Disinfection system	UV & Ozone
Control box with heater	1 – 3000 W
Chromotherapy Leds	Multipoint
Cover	1

WATER CIRCUIT SPECIFICATIONS

Water Capacity	1800 l
Drain Valve	1

ELECTRICAL SPECIFICATIONS

Voltage	220-240 V ~ or 380-415 V ~
Max Absorbed Power	7510 W
Frequency	50 Hz
Amperage	32A or 3x16A

Note : the standard measures may vary ± 2 cm

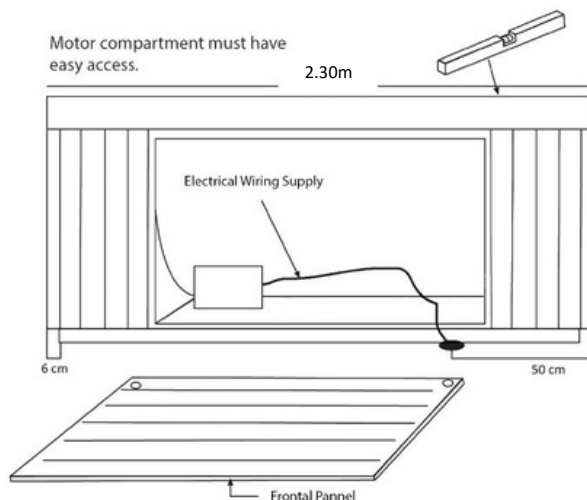

IMPORTANT: Important: The equipment must be connected to an exclusive and permanent power line capable to support installed power. Lighting and electrical receptacles must be located at least 1.5 meters from the equipment. The circuit ground wire must be provided to take advantage of the designed-in safety features of the equipment. The electric installation must be in accordance with actual legislation.