



## RIA R21

### TECHNICAL INFORMATION

Dimensions	2.10 x 2.10 x 0.90 m
Jets	25
Shell	White
Panels	EcoWood
Weight without water	400 Kg
Weight with water	1500 Kg
Volume	3.3 m3

### EQUIPMENT SPECIFICATIONS

Seats	5
Filter	1 (1.1 m2)
Circulation / Massage Pump	1 – 370/1500 W
Massage Pump	-
Blower	-
Disinfection system	Ozone
Control box with heater	1 – 2000 W
Illumintaion	White spot
Cover	1

### WATER CIRCUIT SPECIFICATIONS

Water Capacity	1100 l
Drain Valve	1

### ELECTRICAL SPECIFICATIONS

Voltage	220-240 V ~
Max Absorbed Power	2370 W
Frequency	50 Hz
Amperage	12A

Note : the standard measures may vary  $\pm 2$ cm

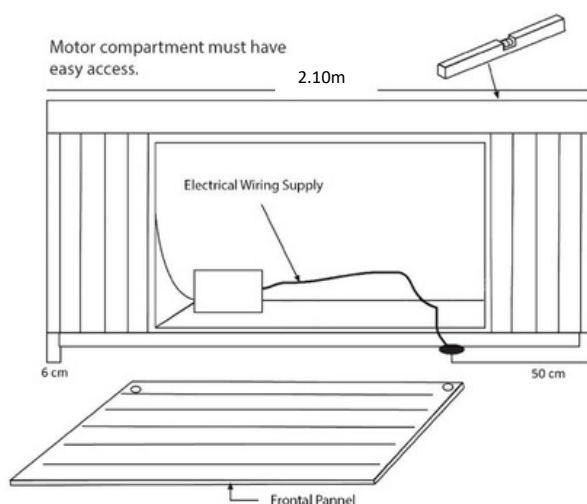

**IMPORTANT:** Important: The equipment must be connected to an exclusive and permanent power line capable to support installed power. Lighting and electrical receptacles must be located at least 1.5 meters from the equipment.

The circuit ground wire must be provided to take advantage of the designed-in safety features of the equipment.

The electric installation must be in accordance with actual legislation.